

# **MYTE (SCC002) Satellite Transmitter**

## **Specification**

### **1.0**

**Prepared By**  
**Sypes Canyon Communications**

**June 2012**



## REVISION HISTORY

Date	Rev	Description	Name
21 Apr 12	1.0	Initial Product Release	GAN



## Table of Contents

1. Description .....	4
2. MYTE Device Theory of Operation.....	5
2.1. Satellite Messaging Method .....	6
3. I2C Serial Host Interface.....	7
4. On-Air Interface .....	8
4.1. RF Modulation.....	8
4.1.1. EMI/EMC Conformance .....	10
4.2 On Air Data Protocol .....	13
4.2.1. On Air Packet Timing.....	14
5. Electrical and Mechanical Specifications .....	16
5.1. Electrical Interface .....	16
5.1.1. RF Transmit Design Guidelines .....	17
5.1.2. Electrical Supply Guidelines .....	18
5.2. Mechanical Interface .....	19
6. Integration Guidelines .....	20
6.1. Regulatory Certifications and MYTE Labeling .....	20
6.2. Globalstar Certifications .....	22
6.3. Antenna Guidelines.....	22
7. Ordering Information.....	24



## 1. Description

The MYTE (SCC002) device is a radio transmitter module that creates the radio frequency (RF) signals to relay small packets of data to the Globalstar Simplex Data Service satellite network. The MYTE serves as a communication gateway in an embedded application to send transmit-only (simplex) data. Data packets are in small, 9-byte segments. The MYTE supports 9, 18, 27 or 36 byte data payloads. The Globalstar Simplex Data Service comprises a set of low-earth-orbit (LEO) satellites operating as bent-pipe data relay devices to ground earth data collection points. This specification stipulates the operational and physical requirements for the MYTE transmitter device that is compatible with this satellite network system.

The MYTE device is the radio transmitter only. The MYTE must be fully integrated into a larger application device to provide utility. This specification provides the physical, electrical and integration requirements to enable application development.

### Definitions / Glossary of Terms

The following definitions used herein shall have the meanings as defined below:

- a) Globalstar: The term “Globalstar” means Globalstar, Inc., a Delaware USA Corporation having offices at 461 South Milpitas Blvd, Milpitas, California 95035
- b) Globalstar Simplex Data Service: The term “Globalstar Simplex Data Service” refers to communications from simplex transmitters relayed over Globalstar’s network of low earth orbit satellites to Globalstar gateways for distribution to end customers.
- c) LEO: The term LEO is an acronym meaning low earth orbit.
- d) GPS: The term GPS is an acronym meaning global positioning system.
- e) RF: Radio Frequency
- f) RTU: Remote Telemetry Unit, generically used as the device that contains the Myte integrated into it as the satellite communication means.
- g) EMI: Electro Magnetic Interference
- h) BPSK: Binary Phase Shift Keyed modulation. This is the data modulation incorporated by the Myte compliant with the Globalstar Simplex Data Service.
- i) DSSS: Direct Sequence Spread Spectrum. This is the spreading method coupled with BPSK
- j) PRS: Pseudo Random Sequence. The digital method for creating the DSSS spreading code.



- k) TCXO: Temperature Compensated Crystal Oscillator.
- l) RAS: Radio Astronomy Service. Regions of restricted frequency use compliant with the Globalstar radio spectrum license.
- m) EVM: Error Vector Magnitude: A measure of BPSK modulation quality.
- n) EIRP: Effective Isotropic Radiated Power.
- o) ESN: Electronic Serial Number. Unique serialization number for each transmitter.

## 2. MYTE Device Theory of Operation

The MYTE device is a radio transmitter module that contains the functionality to accept configuration and data from a host application and convey data to the Globalstar Simplex Data Service satellite system. The block diagram below depicts the integral components of the MYTE device to fulfill this functionality.

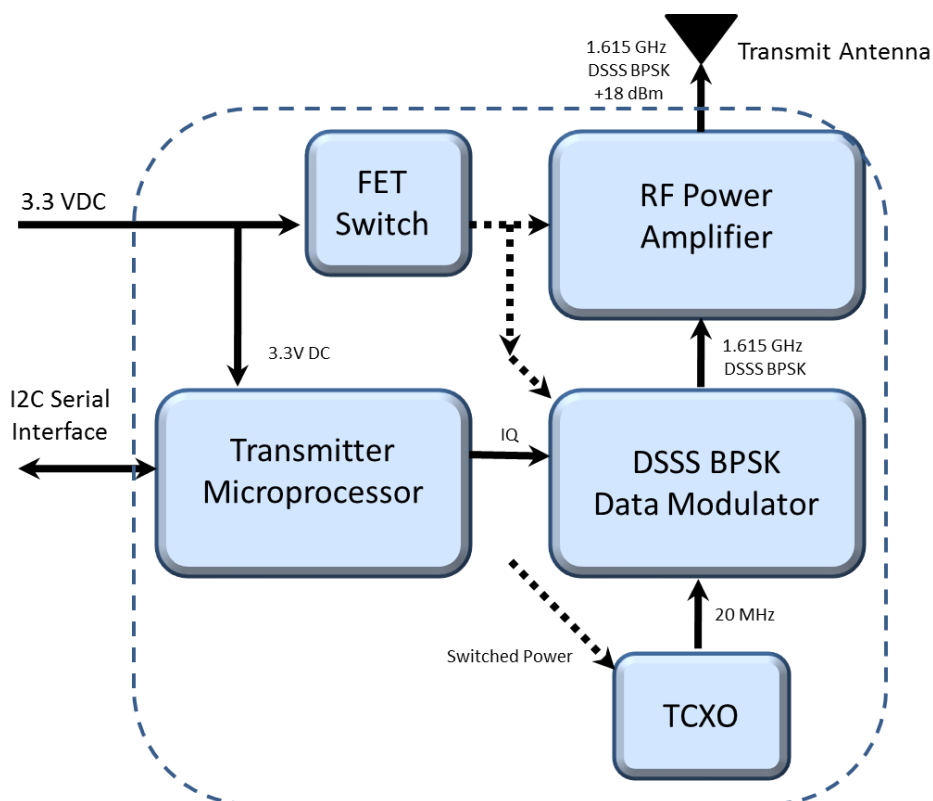

The MYTE module contains a microprocessor that controls the transmitter functions, provides power management and controls the RF transmitter functions. The MYTE module switches the input DC power to create the voltages necessary to minimize power and manage the transmit function.



The microprocessor operates in low power state using an internal 32.768 kHz oscillator. During transmit operations, the microprocessor enables the DC power to the RF circuitry and temperature compensated crystal oscillator (TCXO) to generate the clock reference for the BPSK modulator. The TCXO clock frequency is 20 MHz. The microprocessor also uses the TCXO clock during the transmit process.

The BPSK modulator outputs the transmit signal at frequency to a power amplifier section which provides the signal gain for the transmitter.

The MYTE module is a single layer board assembly measuring  $\frac{1}{2}$ " x  $\frac{3}{4}$ " and interfaces to the host application via a 11 pin surface mount pad-style connector. The connector provides power, I2C serial communications and the RF transmit signal.

The MYTE module depicted below performs the transmit functions described when serially tasked by the host application processor via the I2C serial interface. When idle, the MYTE module assumes a low-power state drawing mere microAmps.

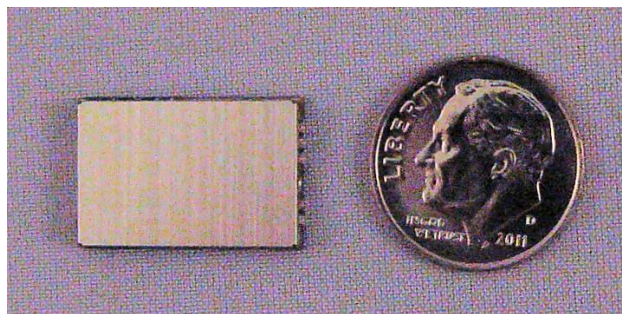

## 2.1. Satellite Messaging Method

The MYTE device manages all the required messaging to be compliant to the Globalstar Simplex Data Service. The application interface need only configure the device once and send data to the MYTE using the I2C serial interface. The MYTE will queue the data to be sent and manage the process of transmitting the data to the satellite system.

Because the messages are transmitted unsolicited and without the benefit of a two-way data link with the satellite system, each message is transmitted several times with a random delay component between transmits of roughly  $7 \pm 2$  minutes. Recommended configuration setting transmits each message three times with time delays between each transmission to allow for the satellite constellation to shift in position. The configuration parameters of the MYTE allow for adjustment of number of transmissions and time delays between transmissions. This overview is provided to briefly demonstrate how the MYTE functions in order for application developers to understand how the simplex system operates. Integrators should know that sending a message for transmit may therefore take up to 20 minutes to complete the transmit sequence. This does not mean that system latency is typically that



long, but because the MYTE has no way to discern if the message was successful on first or subsequent attempts, it will repeat the message transmit per configuration setting. The satellite system will deliver the first received message captured, typically the first message and thus the probabilistic system latency is seconds, not minutes. Nevertheless, on rare occasions the system may miss the first message and the data packet will have a new chance for packet delivery success on subsequent trials.

### 3. I2C Serial Host Interface

The MYTE contains an I2C serial interface that operates in slave mode only in an application system. The external application host processor can configure and send data to the MYTE using this two-wire serial interface. As a slave, the MYTE operates similar to an EEROM device, with configuration and data read/write operations managed by the external host processor. MYTE supports industry standard I2C slave operation up to 100 kbps. Contact Sypes Canyon Communications for the Myte specification which details this communication interface.



## 4. On-Air Interface

The MYTE transmits data in a radio format compatible with the Globalstar Simplex Data Service. This section provides a brief overview of the operation of the network service. Greater detail can be found in the requirements definitions set forth by Globalstar.

### 4.1.RF Modulation

The MYTE transmits data using Direct Sequence Spread Spectrum (DSSS) carrier with a Binary Phase Shift Keyed (BPSK) data modulation. The MYTE can be configured to send data on one of four radio center frequencies. Globalstar operational requirements for channel usage must be observed by application developers. Generally, channel A is used for North American operations except where the device is in proximity of Radio Astronomy Sites (RAS), where channel C is prescribed. Use in other global regions uses channel C. The channels are specified as:

RF Channel
<b>Channel A = 1611.25 MHz center frequency</b>
<b>Channel B = 1613.75 MHz center frequency</b>
<b>Channel C = 1616.25 MHz center frequency</b>
<b>Channel D = 1618.75 MHz center frequency</b>

The DSSS carrier is generated using a pseudo random maximal length feedback shift register utilizing a polynomial code prescribed by Globalstar. This PRS is 8 bits in length, denoting a repetition length of 25 chips.

$$\text{PRS Polynomial} = X^8 + X^6 + X^3 + X^2$$

The epoch is prescribed at the leading edge of an all 1 state of the PRS.

The PRS chip rate is 1.25 Mchip/sec. The frequency accuracy is +/- 2.0 ppm at 25C, with no more than 0.3 ppm error during a transmission of a single packet. Chipping rate and RF frequency are coherent.

The symbol rate is 100.04 bps, derived from 49 PRS code repetitions, with symbol boundary occurring at epoch.

Transmit output power is 18 dBm  $\pm$  2 dB RMS over all operating conditions. The following timing considerations with regard to RF key-on will be observed:

The EVM (Error Vector Magnitude) is less than 15 % RMS for 1020 symbols. This corresponds to an RMS phase error of less than 18 degrees and a magnitude error of less than 10%.





- PRS code must be applied within  $\pm 5$  us of RF key-on
- RF output power is greater than 100 dB below nominal output power for RF key-off
- RF synthesizer is not to be turned on more than 400 us before the RF key-on. Transmit power will be attenuated a minimum of 40 dB from nominal output power during this period.
- RF key-off occurs no later than 10 us following data transmission
- RF power and data modulation is stable within 5 usec of RF key-on
- RF key-off function occurs within 5 usec
- PRS code is disabled no sooner than 5 usec before PA is turned off.
- The MYTE will not transmit if the RF generation circuitry is not locked and modulation is stable.

The diagram below depicts the RF modulation operation timing.

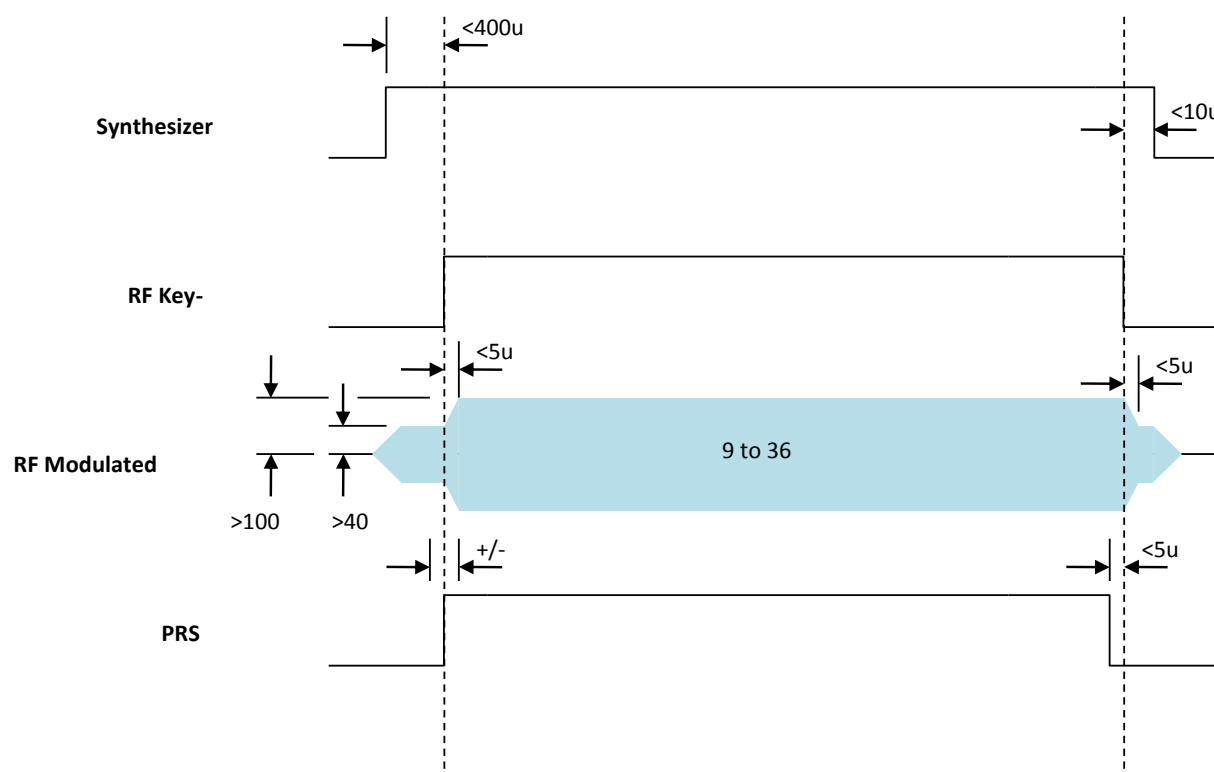

The RF spectrum shall not contain harmonic levels that exceed -20 dBm when measured in a 5 MHz bandwidth. Non-harmonic related discrete spurs shall not exceed -30 dBm when measured in a 100 KHz bandwidth.



### 4.1.1. EMI/EMC Conformance

The MYTE shall carry an FCC 25 modular device certification, stipulating a maximum antenna gain of +5 dBi. In addition, the Myte shall be verified compliant to FCC part 15 and EN 301-441 for EU use.

#### FCC Part 15.109

FCC Part 15.109 Summary lists the spectrum limits when the MYTE is actively processing data but not transmitting.

**FCC Part 15.109 Summary**

Absolute Frequency	Offset from Carrier	EIRP	Measurement Bandwidth / Method
30 to 88	-	90 $\mu\text{V}/\text{m}$	10 meters
88-216	-	150 $\mu\text{V}/\text{m}$	10 meters
216-960	-	210 $\mu\text{V}/\text{m}$	10 meters
Above 960	-	300 $\mu\text{V}/\text{m}$	10 meters

#### Part 25.202

Part 25.202 Summary lists the FCC spectrum limits when the MYTE is transmitting.

**Part 25.202 Summary**

Absolute Frequency	Offset from Carrier	EIRP	Measurement Bandwidth / Method
Frequency Offset (Authorized bandwidth 2.5 MHz)	Below -6.25 MHz	-35 dBc	4 KHz Average
	-6.25 to -1.25 MHz	-35 dBc	4 KHz Average
	-2.5 to -1.25 MHz	-25 dBc	4 KHz Average
Frequency Offset (Authorized Bandwidth 2.5 MHz)	1.25 to 2.5 MHz	-25 dBc	4 KHz Average
	2.5 to 6.25 MHz	-35 dBc	4 KHz Average
	Above 6.25 MHz	-35 dBc (Assuming 18dBm output power)	4 KHz Average



**EN 301-441**

Part 25.202 **Summary** lists the EU spectrum limits when the MYTE is transmitting.

**EN 301-441 Summary**

Absolute Frequency	Offset from Carrier	EIRP	Measurement Bandwidth / Method
0.1 to 30		-36 dBm	10 KHz Peak-Hold
30 to 1000		-36 dBm	100 KHz Peak-Hold
1000 to 1559		-30 dBm	1 MHz Average
1559 to 1580.42		-40 dBm	1 MHz Average
1580.42 to 1605		-40 dBm	1 MHz Average
1605 to 1610		-40 dBm to 20 dBm <sub>1</sub>	1 MHz Average
Frequency Offset (Does not apply below 1610 MHz)	-17.75 to -3.05 MHz	-26 dBm	30 KHz Average
	-3.05 to -2.165 MHz	-26 dBm to -23 dBm <sub>1</sub>	30 KHz Average
	-2.615 to -1.9 MHz	-15 dBm	30 KHz Average
	-1.9 to -1.475 MHz	-15 dBm to -8.5 dBm <sub>1</sub>	30 KHz Average
	-1.475 to -1.41 MHz	-8.5 dBm to -5 dBm <sub>1</sub>	30 KHz Average
Frequency Offset (Does not apply above 1628.5 MHz)	-1.41 to -1.25 MHz	-5 dBm	30 KHz Average
	1.25 to 1.41 MHz	-5 dBm	30 KHz Average
	1.41 to 1.475 MHz	-5 dBm to -8.5 dBm <sub>1</sub>	30 KHz Average
	1.475 to 1.9 MHz	-8.5 dBm to -15 dBm <sub>1</sub>	30 KHz Average
	1.9 to 2.615 MHz	-15 dBm	30 KHz Average
1628.5 to 1631.5	2.615 to 3.05 MHz	-23 dBm to -26 dBm <sub>1</sub>	30 KHz Average
	3.05 to 17.75 MHz	-26 dBm	30 KHz Average
1631.5 to 1636.5		-30 dBm	30 KHz Average
1636.5 to 1646.5		-30 dBm	100 KHz Average
1646.5 to 1666.5		-30 dBm	300 KHz Average
1666.5 to 2200		-30 dBm	1 MHz Average
2200 to 12,750		-30 dBm	3 MHz Average
		-30 dBm	3 MHz Peak Hold

<sup>1</sup> Limit in dB varies linearly

The graphs below depict the FCC part 25 and ETSI occupied channel bandwidth performance with limits shown compliant to the tables above.



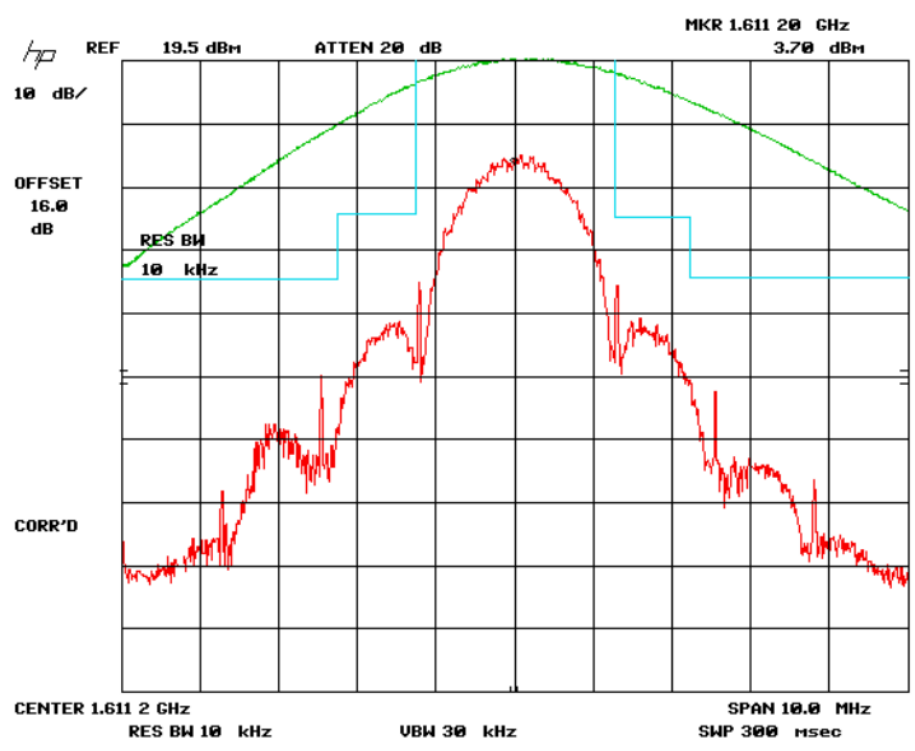

**FCC Part 25 Occupied Bandwidth and Emissions Limitations (FCC Sec. 2.1049, 25.202(f))**

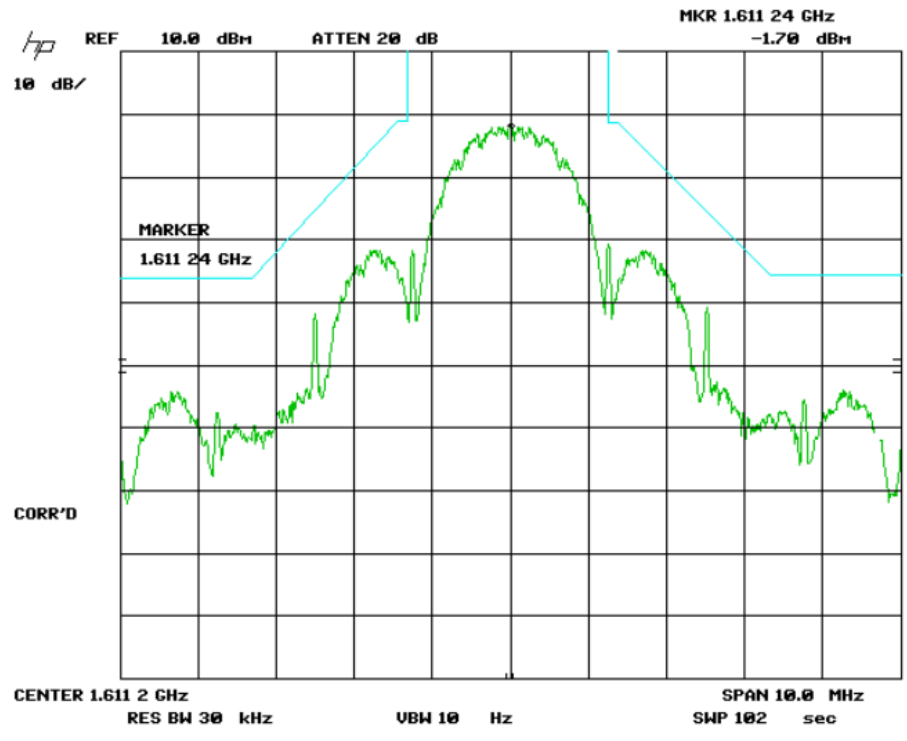

**ETSI Unwanted Emissions Within the band (sub-clause 5.2.3)**

## 4.2 On Air Data Protocol

The MYTE transmits data in a radio format compatible with the Globalstar Simplex Data Service. This section provides a brief overview of the operation of the network service. Greater detail can be found in the requirements definitions set forth by Globalstar.

On air data is a structured protocol encapsulating user payload data. Each on air burst contains 9 bytes of user payload data. Longer user payloads are broken into multiple on air bursts, each containing 9 of the user payload bytes. Each on air burst is structured as depicted below.

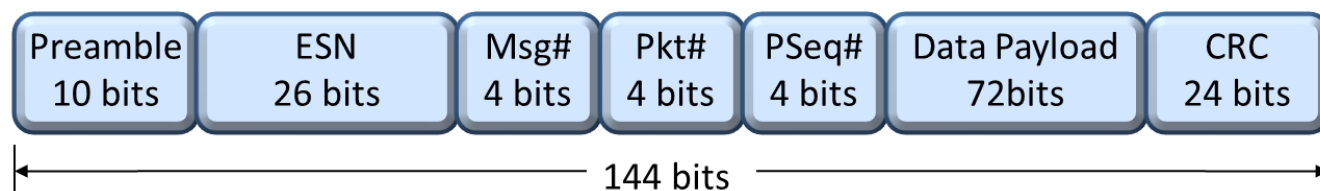

All fields are transmitted MSBit first.

**Preamble:** The preamble is a 10 bit sequence equal to 0000001011 with the leftmost binary bit sent first.

**ESN:** The ESN contains 3 MSbits of manufacture ID and 23 LSbits of serial number. The MSbit is sent first.

**Message #:** The message number is a modulo 16 counter that is incremented on each new unique message. All RF bursts and subsequent repeats of bursts contain the same message. Message # is non-volatile. Removing power from the MYTE does not reset this counter value, nor is it reset on configuration.

**Packet#:** Contains the total number of packets in a message. Messages larger than 9 bytes will be sent using multiple bursts. A Packet# of 0 indicates a 9 byte user payload, 1 = 18 byte payload, 2 = 27 byte payload and 3 = 36 byte payload. All bursts of the message will hold the same Packet# count.

**Packet Sequence#:** The Packet Sequence# indicates the count of the burst in a multi-burst message. 9 byte payloads will be transmitted in a single burst with a PacketSequence# of 0.

**Data Payload:** DataPayload contains the application user data in 9 byte blocks.

**CRC:** The CRC is the burst data checksum used to qualify the data. The CRC does not include the preamble but all other fields. The 24 bit CRC uses the seed polynomial 114377431.



The following software example provides the method for generating the 24 bitCRC for the on-air message.

```

int k,m;
unsigned long Crc, TempCRC

Crc = 0xFFFFFFFF;

for(k=0; k<14; k++)      // calc checksum on 14 bytes starting with esn
{
    TempCRC = TX_Data[k];
    if(k == 0)
        TempCRC &= 0x3f; // skip 2 preamble bits in byte0

    Crc ^= (TempCRC)<<16;

    for(m=0; m<8; m++)
    {
        Crc <<=1;
        if(Crc & 0x1000000)
            Crc ^= 0114377431L; // seed CRC
    } // end for m loop
} // end for k loop

Crc = (~Crc) & 0xffffffff;
//end crc generation. lowest 24 bits of the long hold the CRC

TX_Data[14] = (Crc & 0x00ff0000) >> 16; // first CRC byte to TX_Data
TX_Data[15] = (Crc & 0x0000ff00) >> 8; // second CRC byte to TX_Data
TX_Data[16] = (Crc & 0x000000ff); // third CRC byte to TX_Data

```

#### 4.2.1. On Air Packet Timing

Each message is sent over the air redundantly as specified in the configuration byte (see section 3.11). Typically, and as recommended by Globalstar, each message is transmitted a total of 3 times. For a 9 byte payload, the on-air message transmission will be sent as depicted below.

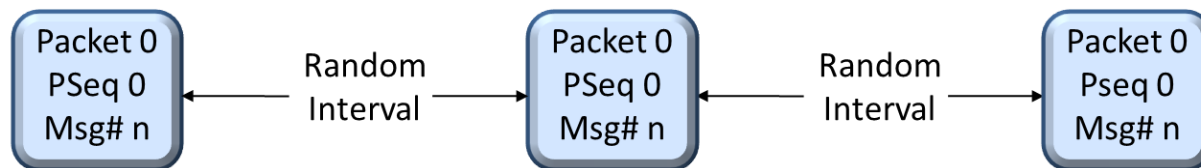

The Random interval is set by the Retry Interval configuration (see section 3.12). For the standard retry interval of up to 10 minutes, it can take as long as 20 minutes to send a message with the redundant packets.

If the data payload is 18 bytes, the payload is broken into two 9 byte packets and transmitted as depicted below.

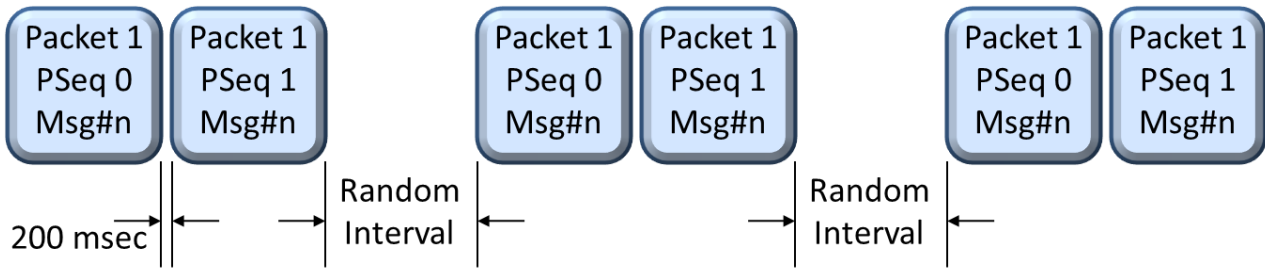

## 5. Electrical and Mechanical Specifications

This section provides the mechanical and electrical requirements for the integration of the MYTE into a host application.

### 5.1. Electrical Interface

The MYTE is a board-level module that integrates into the host application via a 11-pad connector.

**Transmit Process**

Pin	Description	Note
1	VCC	Power Input = 3.3V +/- 5%
2	SCL	I2C Serial Clock (externally pull to VCC)
3	SDA	I2C Serial Data (externally pull to VCC)
4	XRES	External Reset input – active high
5	BUSY	BUSY output signal
6	SwEn	SwEn output signal
7	Ground	
8	Ground	
9	Ground	
10	RF Out	50 Ohm RF output to Globalstar antenna
11	Ground	

#### MYTE Pin Definitions:

**VCC** - (MYTE input power): VCC voltage supply is 3.3V +/- 5%. This voltage must be supplied and regulated to the MYTE for all operations. Transient response between operating modes must be limited to less than 5 usec.

**SCL** – (I2C clock): Serial data clock signal. 100 Kbaud I2C compliant.

**SDA** – (I2C data): Serial data signal. 100 Kbaud I2C compliant.

**XRES** - (external reset input): Active high reset input. Host application should typically hold this low. A high signal will force a hardware reset to MYTE.

**BUSY** – : The BUSY pin will output high while the MYTE is in an active transmit operation. This pin will remain high until the message has been completely transmitted, including remaining high between any configured redundant bursts. See diagram below.





**SwEn:** The SwEn pin will output high while the MYTE is in an active RF transmit operation. This mode supports using the signal to trigger an external power supply (such as a switcher) coincident with higher power required for RF bursts. This pin will remain high only while the MYTE has enabled the RF transmitter. It will return low at the end of the RF transmission and between any configured redundant bursts. SwEn will transition low-to-high at least 50 usec prior to each RF message burst. See diagram below.

**RF\_Out** – (Transmit signal output): This is the 50 Ohm RF output signal. It should be connected to a 50 Ohm trace or connector as close to the MYTE as possible.

**GND** – (RF Ground): The multiple GND pads should be tied to application ground plane.

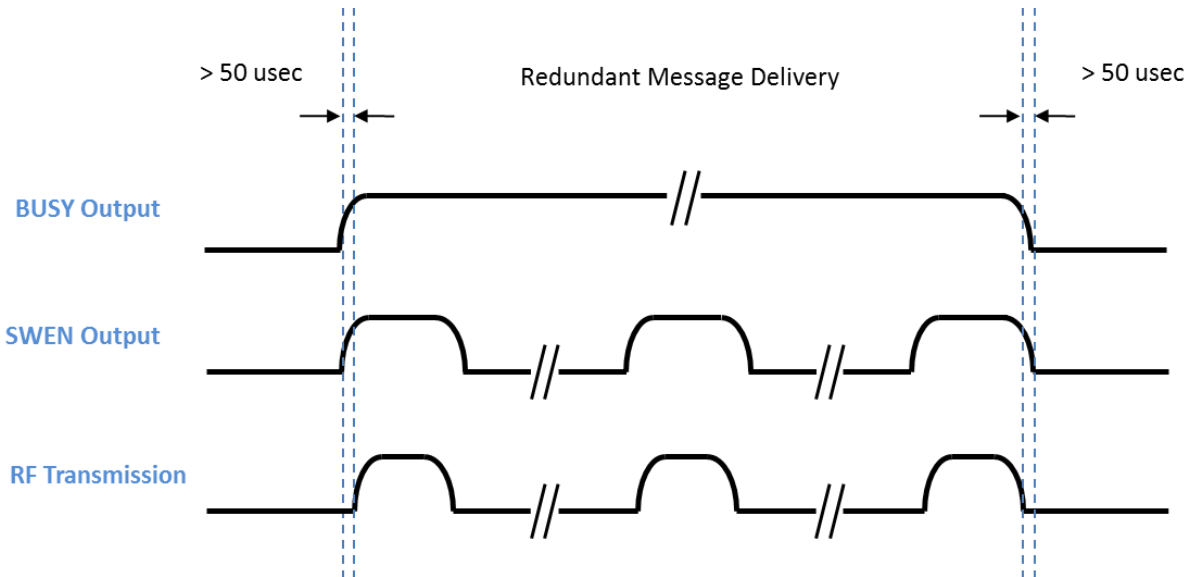

### 5.1.1. RF Transmit Design Guidelines

The MYTE sends the RF transmit signal through one of the pins on the connector. In order to avoid signal loss, the signal should be routed through a 50 Ohm coplanar or stripline RF signal path in the application design. For example, for 0.062" FR4 circuit assemblies, this may be achieved using a 60 mil RF trace with a 15 mil gap to stitched ground skirt on top of ground on opposite side of the board. Designers should completely evaluate the impedance of the RF trace to avoid signal power loss.



### 5.1.2. Electrical Supply Guidelines

The MYTE has dynamic power management features, idling at microAmps but requiring pulse current on radio transmit. The power supply feeding the MYTE must be 3.3V +/- 5% and able to source 400 mA of supply current within 5 usec of transmit start without drooping supply voltage below 3.1V.

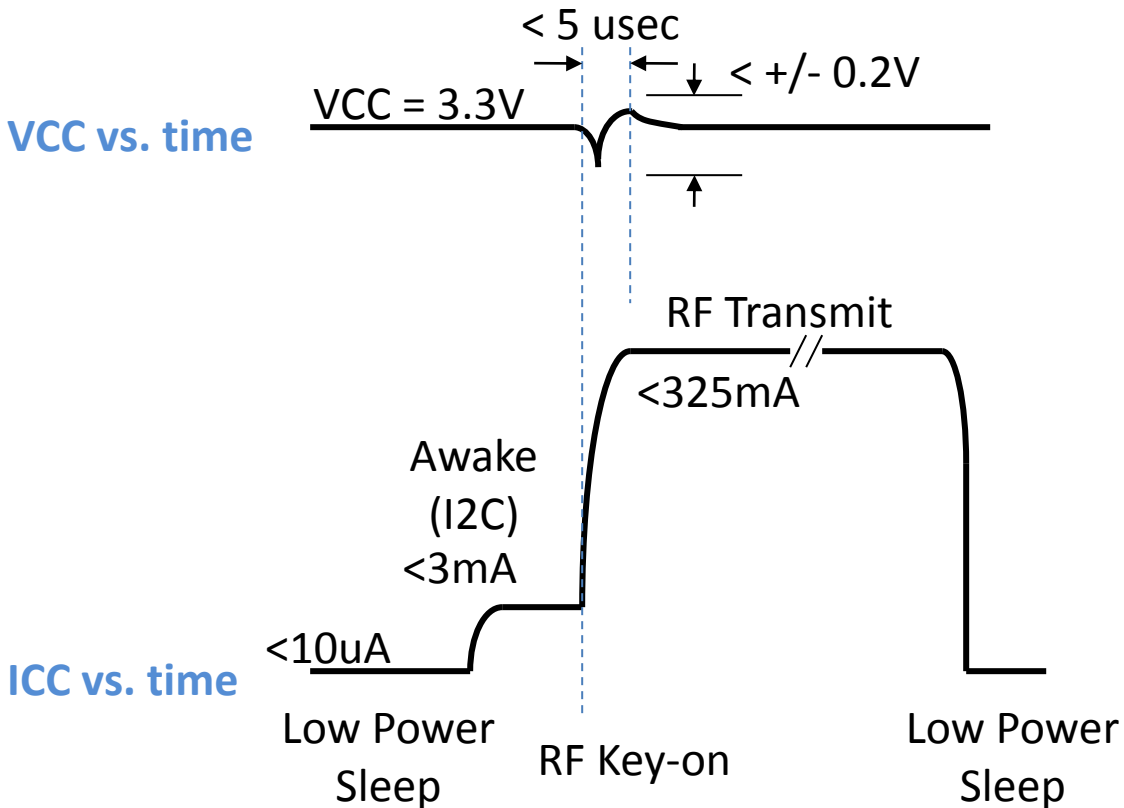

## 5.2.Mechanical Interface

The MYTE is a board-level module that integrates into the host application via the surface mount pads shown below. The MYTE top-side host solder footprint is shown below.

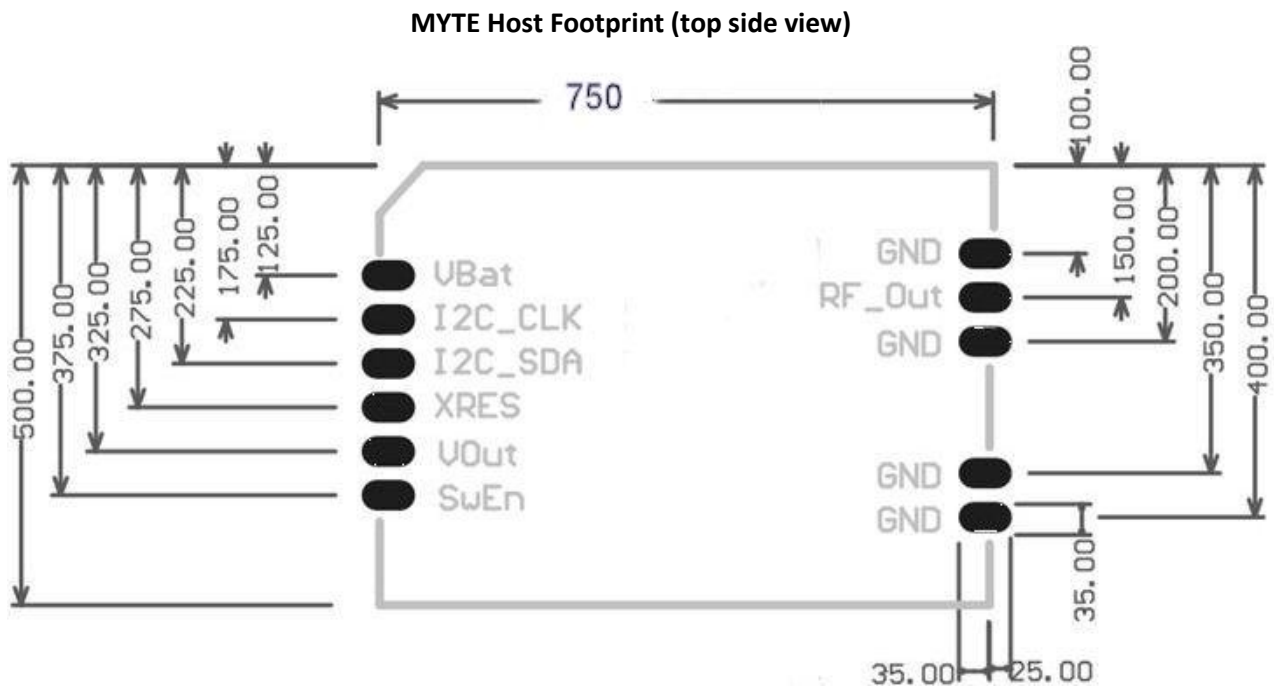

All dimensions in mils (thousandths of an inch).

The MYTE is an RF module assembly. Care should therefore be taken in application design to ensure the power and data signals are electrically clean. Running RF or digital signals under the MYTE module is not advised. It is preferred to provide a solid ground plane on the top layer of the application board layout.



## 6. Integration Guidelines

Integrating the MYTE into an application requires compliance with the network operation guidelines as set forth by Globalstar. This section highlights the primary guidelines and restrictions, however users must consult with Globalstar for any updates or changes to operation that govern use of the Simplex Satellite service.

### 6.1. Regulatory Certifications and MYTE Labeling

The application that incorporates the MYTE device must be properly certified for the region of operation. MYTE will carry modular certifications for FCC and IC and be tested to conformity for EU use, but the integrator must confirm operation of the final integrated unit in compliance with the modular use and regional regulatory restrictions including the required marking of the end device. It remains the responsibility of the integrator to ensure all necessary certifications, documentation and tests are performed for the integrated MYTE. The MYTE device (Model SCC-002) is marked with the FCC ID and IC certification number as shown below.



actual size of the label is 1/2" x 1/2"

Each MYTE transmitter label will also contain a Micro-QR barcode and human readable Electronic Serial Number (ESN). The left-most digit in the labeled ESN is the manufacture ID, so as shown above, the ESN is 2-3000045. The ESN notation is decimal, with the Manufacture ID weighted as  $2^{23}$ . The formula below provides the conversion for the ESN labeling to hexadecimal notation used in ESN reads from the MYTE (see section 3.1.3).

$$ESN_{hex} = (MFG\_ID * 2^{23}) + ESN_{dec}$$

For the example label above:



$$\text{ESN}_{\text{hex}} = 0x012DC6ED = (2 * 2^{23}) + 3000045$$

When the MYTE is incorporated into a product, it must be appropriately labeled. The application designer must ensure the product labeling is accurate and complete. At a minimum, it must contain a statement or marking to designate the device contains the radio transmitter.

“Contains Transmitter Module FCC ID: ZBR002” or

“Contains FCCID: ZBR002”

Consult the regulatory requirements for product marking for the latest requirements for each region or application for the application product to ensure compliance.

**Note Well: This equipment has been tested and found to comply with the limits for a Class B device, pursuant to part 15 of the FCC Rules. These limits are designed to provide reasonable protection against harmful interference in a residential installation. This equipment generates, uses and can radiate radio frequency energy and, if not installed and used in accordance with the instructions, may cause harmful interference to radio communications.**

**However, there is no guarantee that interference will not occur in a particular installation. If this equipment does cause harmful interference to radio or television reception, which can be determined by turning the equipment off and on, the user is encouraged to try to correct the interference by one or more of the following measures:**

- Reorient or relocate the receiving antenna.
- Increase the separation between the equipment and receiver.
- Connect the equipment into an outlet on a circuit different from that to which the receiver is connected.
- Consult the dealer or an experienced radio/TV technician for help.

**Caution: Changes or modifications not expressly approved by the party responsible for compliance could void the user's authority to operate the equipment**



## 6.2. Globalstar Certifications

The application that incorporates the MYTE device must be properly approved for use by Globalstar before use over their network. This will include proper channelization for regional use and other radio telemetry requirements. Contact Globalstar for RTU certification procedures. Special attention must be given to channelization of use as specified in Globalstar document GS-07-1248.

## 6.3. Antenna Guidelines

The MYTE may be integrated with an antenna with a maximum directivity gain of +5dBi, such as the Spectrum Advanced Specialties Products antenna part number **PA25-1615-025SA** or **PA451615-1575SA** (dual band sat+gps) or **TW2515** from Tallysman Wireless.

### Note:

If the Myte is to be integrated into a device to be used in Canada, the required notices are specified in the RSS documents (including RSS-Gen) applicable to the equipment model. These notices are required to be shown in a conspicuous location in the user manual for the equipment, or to be displayed on the equipment model. If more than one notice is required, the equipment model(s) to which each notice pertains should be identified. Suppliers of radio apparatus shall provide notices and user information in both English and French.

*Under Industry Canada regulations, this radio transmitter may only operate using an antenna of a type and maximum (or lesser) gain approved for the transmitter by Industry Canada. To reduce potential radio interference to other users, the antenna type and its gain should be so chosen that the equivalent isotropically radiated power (EIRP) is not more than that necessary for successful communication.*

*Conformément à la réglementation d'Industrie Canada, le présent émetteur radio peut fonctionner avec une antenne d'un type et d'un gain maximal (ou inférieur) approuvé pour l'émetteur par Industrie Canada. Dans le but de réduire les risques de brouillage radioélectrique à l'intention des autres utilisateurs, il faut choisir le type d'antenne et son gain de sorte que la puissance isotrope rayonnée équivalente (p.i.r.e.) ne dépasse pas l'intensité nécessaire à l'établissement d'une communication satisfaisante.*

The above notice may be affixed to the device instead of displayed in the user manual.



User manuals for transmitters equipped with detachable antennas shall also contain the following notice in a conspicuous location:

*This radio transmitter (identify the device by certification number, or model number if Category II) has been approved by Industry Canada to operate with the antenna types listed below with the maximum permissible gain and required antenna impedance for each antenna type indicated. Antenna types not included in this list, having a gain greater than the maximum gain indicated for that type, are strictly prohibited for use with this device.*

*Le présent émetteur radio (identifier le dispositif par son numéro de certification ou son numéro de modèle s'il fait partie du matériel de catégorie I) a été approuvé par Industrie Canada pour fonctionner avec les types d'antenne énumérés ci-dessous et ayant un gain admissible maximal et l'impédance requise pour chaque type d'antenne. Les types d'antenne non inclus dans cette liste, ou dont le gain est supérieur au gain maximal indiqué, sont strictement interdits pour l'exploitation de l'émetteur.*

User manuals for licence-exempt radio apparatus shall contain the following or equivalent notice in a conspicuous location in the user manual or alternatively on the device or both.

*This device complies with Industry Canada licence-exempt RSS standard(s). Operation is subject to the following two conditions: (1) this device may not cause interference, and (2) this device must accept any interference, including interference that may cause undesired operation of the device.*

*Le présent appareil est conforme aux CNR d'Industrie Canada applicables aux appareils radio exempts de licence. L'exploitation est autorisée aux deux conditions suivantes : (1) l'appareil ne doit pas produire de brouillage, et (2) l'utilisateur de l'appareil doit accepter tout brouillage radioélectrique subi, même si le brouillage est susceptible d'en compromettre le fonctionnement.*



## 7. Ordering Information

The MYTE manufacturing is established at the following vendor(s). The device may be procured from the vendor(s) listed.

<b>MYTE Source</b>	
<b>MYTE Authorized Vendor</b>	<b>Part Number</b>
<b>Sypes Canyon Communications 707 Bridger Dr. Suite C Bozeman, MT 59715 (406) 522-1105</b>	<b>SCC-002</b>